



solutions creator



Gabbia di gonfiaggio per ruote da autocarro

Safety inflation cage for truck wheels

Cage de gonflage pour roues de camions

Jaula de inflado para ruedas de camiones

Reifenfüllkäfig für LKW-Räder

IC BOX



La speciale struttura composta da barre in ferro e rete a forma di alveare rende la gabbia di gonfiaggio IC BOX estremamente sicura, poiché la pressione generata dall'eventuale esplosione del pneumatico viene contenuta dalla gabbia e la fuoriuscita di frammenti viene estremamente ridotta, limitando così al minimo i danni all'operatore.

Its special structure consisting of iron bars and a beehive-shaped network makes the inflation cage IC BOX extremely safe, because the pressure generated by any eventual tire explosion is contained by the cage and the leakage of fragments is extremely limited, thus reducing any damage to the operator.

Sa structure spéciale composée de barres en fer et un réseau ressemblant une ruche, rend la cage de gonflage IC BOX extrêmement sûre, parce que la pression générée par une éventuelle explosion du pneu est contenue par la cage et la perte des fragments est extrêmement réduite, en limitant ainsi les dommages à l'opérateur.

Una estructura especial que consiste en barras de hierro y una red con la forma de una colmena, hace la jaula de inflado IC BOX extremadamente segura, porque la presión generada de una posible explosión del neumático está contenida por la jaula y la fuga de los fragmentos es extremadamente reducida, lo que limita al mínimo los daños al operador.

Der Reifenfüllkäfig IC BOX ist extrem sicher, dank seiner speziellen Struktur, bestehend aus Eisenstangen und einem Bienenstockförmigen Netzwerk. Der Druck der eventuellen Explosion des Reifens wird durch den Käfig enthalten und die Leckage von Fragmenten wird extrem verringert. Die Schaden an den Betreiber werden damit stark reduziert.



Valvola di sicurezza che permette all'operatore di gonfiare il pneumatico soltanto a porta chiusa.

Safety valve that allows the operator to inflate the tire only when the door is closed.

Soupape de sécurité qui permet à l'opérateur de gonfler le pneumatique uniquement lorsque la porte est fermée.

Válvula de seguridad que permite al operador de inflar el neumático solamente con la puerta cerrada.

Ein Sicherheitsventil ermöglicht dem Bediener, den Reifen nur bei geschlossener Tür aufzublasen.

Ingombri macchina - Maximum overall dimensions - Dimensions d'encombrement - Dimensiones máquina - Maschinenabmessungen

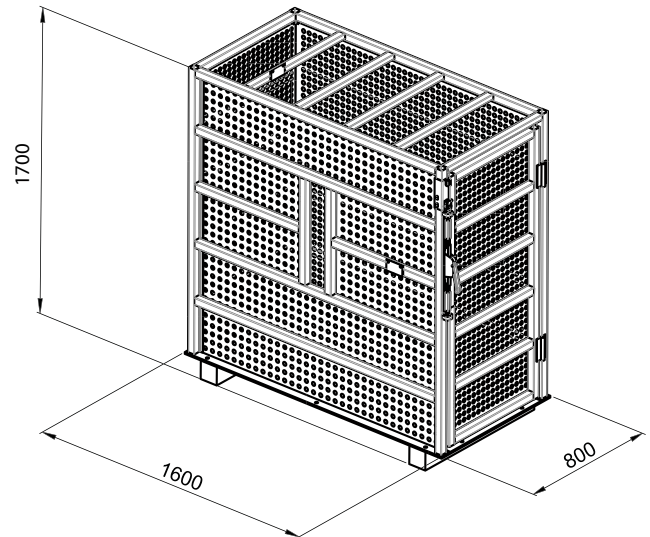
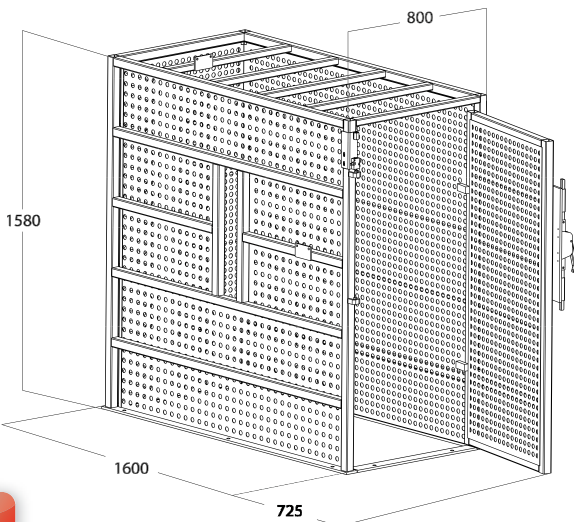

175 Kg



Tyre Equipment & Tools

IT0802000001747



Made in Correggio

ITALY

M&B Engineering srl - Via della Costituzione, 49 - 42015 Correggio (RE) - Tel. +39 0522 644511 - Fax +39 0522 644512

www.mbenengineering.info / info@mb-re.it