



SNIPER WA85

COMBINED CAR-TRUCK CCD WHEEL ALIGNMENT SYSTEM



SNIPER WA85

COMBINED CAR-TRUCK CCD WHEEL ALIGNMENT SYSTEM

Industrial computer
with WINDOWS 10
operating system

Monitor 27" TFT, colour
printer, mouse and
keyboard

CCD
car/truck
sensors

Clamps
12" - 24"

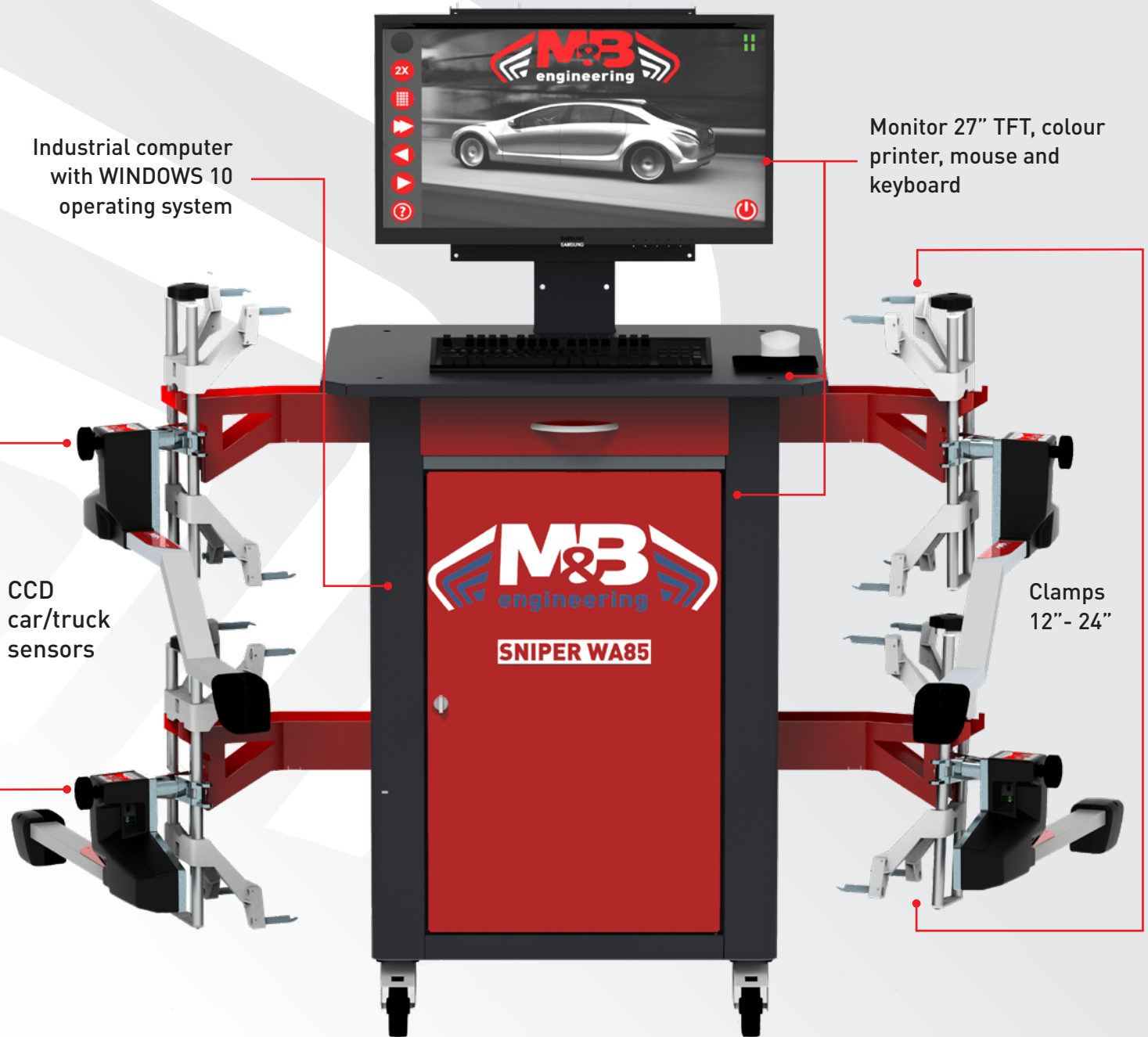

User friendly interface

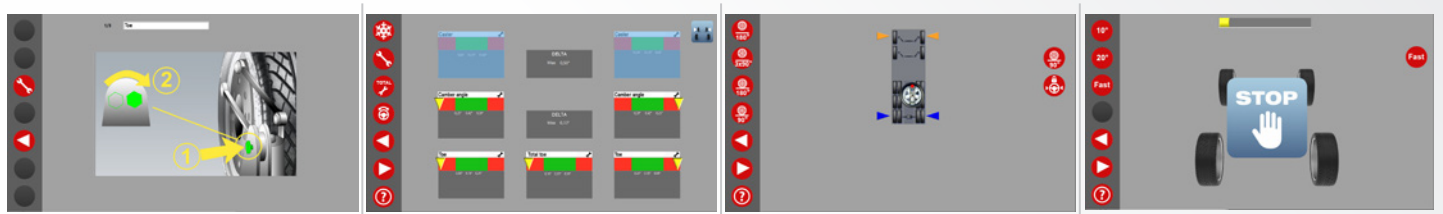

FEATHERWEIGHT SENSORS

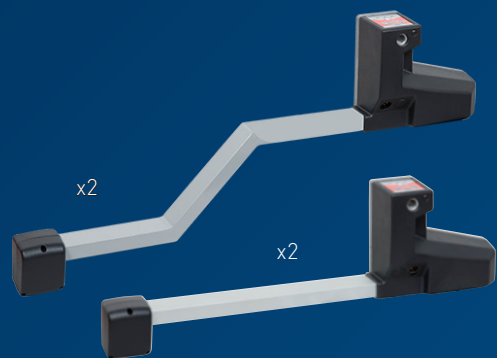

- 🇬🇧 **Detectors** with low weight (2.6/2.8 kg) and **easy to use**
- 🇮🇹 **Rilevatori** con peso ridotto (2.6/2.8 kg) e **pratici da usare**
- 🇫🇷 **Détecteurs** avec poids réduit (2.6/2.8 kg) et **simples à utiliser**
- 🇩🇪 **Messköpfe** mit geringem Gewicht (2.6/2.8 kg) und **praktischer Handhabung**
- 🇪🇸 **Detectores** con peso reducido (2.6/2.8 kg) y **prácticos de utilizar**

🇬🇧 **M&B SNIPER WA85** is the hybrid alignment system suitable for both cars and trucks. Thanks to the intuitive software and to the 8-sensor CCD supported by the most modern transmission technology, the machine allows a quick and accurate measurement of wheel alignment

🇮🇹 **M&B SNIPER WA85** è il sistema di allineamento ibrido adatto sia a vetture che ad autocarri. Grazie al software intuitivo e ai rilevatori CCD a 8 sensori, supportati dalla più moderna tecnologia di trasmissione, la macchina permette una misurazione rapida e precisa dell'assetto ruote

🇫🇷 **M&B SNIPER WA85** est le système d'alignement hybride adapté aux voitures et aux camions. Grâce au logiciel intuitif et aux détecteurs CCD à 8 capteurs, supportés par la technologie de transmission la plus moderne, la machine permet une mesure rapide et précise de l'alignement des roues

🇩🇪 **M&B SNIPER WA85** ist das Hybrid-Achsvermessung für PKWs und für LKWs. Dank der intuitiven Software und der mit Sensoren ausgestatteten 8 CCD-Messköpfe und unterstützt von modernster Übertragungstechnologie ermöglicht die Maschine eine schnelle und präzise Messung der Achsausrichtung

🇪🇸 **M&B SNIPER WA85** es el sistema de alineación híbrido adecuado tanto para coches como para camiones. Gracias al software intuitivo y a los detectores CCD de 8 sensores, soportados por la más moderna tecnología de transmisión, la máquina permite una medición rápida y exacta del alineamiento de las ruedas

🇬🇧 **8 CCD sensors with solar filter** for use also in sunny places and with **enhanced LEDs**

Lithium batteries for an extended working autonomy

Radio communication between detectors and PC always **stable** also in environments with interferences

Database constantly updated and customizable with customers and vehicles

Detailed displays with clear indication of set points

🇮🇹 **8 sensori CCD con filtro solare** per l'utilizzo anche in ambienti soleggiati e con **led potenziati**

Batterie al litio per una prolungata autonomia di lavoro

Comunicazione radio tra rilevatori e pc sempre **stabile** anche in ambienti con interferenze

Banca dati in costante aggiornamento e personalizzabile con clienti e veicoli

Visualizzazioni dettagliate con chiara indicazione dei punti di regolazione

🇫🇷 **8 capteurs CCD avec filtre solaire** pour l'utilisation même dans des environnements ensoleillés et **LED améliorés**

Batteries au lithium pour une autonomie de travail prolongée

Communication radio entre détecteurs et PC toujours **stable** même dans des environnements avec interférences

Banque de données en mise à jour constante et pouvant être personnalisée avec des clients et des véhicules

Affichages détaillés avec indication claire des points de réglage

🇩🇪 **8 CCD-Sensoren mit Solarfilter** für den Einsatz auch in sonniger Umgebung und **Verbesserte LEDs**

Lithiumbatterie für eine verlängerte Autonomie

Die **Funkkommunikation** zwischen Melder und PC ist auch in störenden Umgebungen immer **stabil**

Datenbank ständig aktualisiert und an Kunden und Fahrzeuge anpassbar

Detailanzeigen mit eindeutiger Anzeige der Sollwerte

🇪🇸 **8 sensores CCD con filtro solar** para que se pueda utilizar incluso en ambientes soleados y **Led potenciados**

Baterías al litio para una duración prolongada

Comunicación radio entre detectores y ordenadores siempre **estable** incluso en ambientes con interferencias







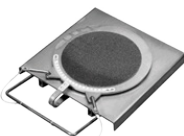

Banca de datos actualizada constantemente y personalizable con clientes y vehículos

Visualizaciones detalladas con indicación clara de los puntos de ajuste

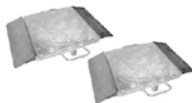
STANDARD CONFIGURATION

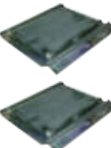
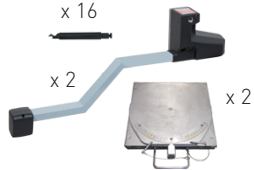

OPTIONAL ACCESSORIES

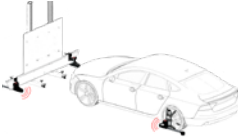
				
2 standard mechanical turnplates 1,0T	2 premium turnplates 1,0T with paddles for car	Turnplates for truck and bus 3,5T	Set of 4 ramps for truck turnlates	Car databank update
				
Set of 4 universal and selfcompensating quick wheel clamp 13"÷ 28"	Calibration Kit complete with HD targets and spirit level to calibrate the cameras	Pair of rear swinging platforms	Truck upgrading kit	Truck databank update
				
Car upgrading kit	ADAS positioning system			

OVERALL DIMENSIONS

