



# MB900P

SUPER FAST FULLY AUTOMATIC WHEEL BALANCER



# 6,4"

## In a measuring cycle it detects:

- wheel dimensions and correction planes
- unbalance measurement
- rim and tyre runout measurement
- Direct Matching - Hubmatch®
- One Plane Balancing

 M&B MB900P is the super automatic balancer for exceptional precision results and unprecedented speed

 M&B MB900P è l'equilibratrice super automatica per risultati di precisione eccezionali ed una velocità senza precedenti

 M&B MB900P est l'équilibreuse super automatique pour une précision exceptionnelle et une vitesse sans précédent

 M&B MB900P ist der superautomatische Auswuchtmaschine für außergewöhnliche Präzisionsergebnisse und beispiellose Geschwindigkeit

 M&B MB900P es la equilibradora súper automática para resultados de precisión excepcionales y una velocidad sin precedentes



# INNOVATIVE SOFTWARE



The OPB (One Plane Balancing) program, if the right conditions, automatically indicates the exact point inside the rim where it is possible to balance the wheel minimizing both static and dynamic imbalance, using only one counterweight



AutoAdaptive software detects wheel weight and dimensions and calculates the tolerance value that will cancel any vibration perceived on the steering wheel, granting the highest comfort when driving

- 3D Laser Scan:** touchless wheel distance and diameter measuring system which detects with extraordinary accuracy and speed the dimensions of any profile. The laser pointer indicates the exact position for stick-on weights application inside the rim, granting the greatest accuracy during the correction  
**Sonar system** for automatic detection of rim width  
**Even faster automatic wheel positioning and locking** of the wheel in weight position  
**OPB (One Plane Balancing):** if the right conditions, OPB automatically indicates the exact point inside the rim where it is possible to balance the wheel minimizing both static and dynamic imbalance, using only one counterweight  
**AutoAdaptive Mode:** detects wheel weight and dimensions and calculates the tolerance value that will cancel any vibration perceived on the steering wheel, granting the highest comfort when driving  
**Side Laser:** line laser indicator on the upper part of the wheel to ease the application of clip-on weights in the exact position  
**Sonar EMS** (1st Harmonic and Peak to Peak) Automatic and quick eccentricity measurement during the normal balancing cycle with fast indication of possible matching and HubMatch  
**Pneumatic wheel locking** which grants floor to floor time reduction and accurate wheel centering
- 3D Laser Scan:** sistema touchless di misura distanza e diametro della ruota che rileva con estrema accuratezza e velocità le dimensioni di qualsiasi profilo. Il puntatore laser indica la corretta posizione per l'applicazione dei pesi adesivi, garantendo la massima precisione in fase di correzione  
**Sistema Sonar** per la rilevazione automatica della larghezza cerchio  
**Posizionamento automatico ancora più veloce e blocco della ruota** nel punto di applicazione dei pesi  
**OPB One Plane Balancing:** sistema che, nel caso ci siano le condizioni, indica il punto di applicazione del peso all'interno del cerchio, permettendo di eliminare lo squilibrio statico e dinamico con un unico contrappeso  
**AutoAdaptive Mode:** acquisisce peso e dimensioni della ruota e ricalcola il valore di tolleranza tale da annullare ogni vibrazione percepita sul volante, assicurando il maggior comfort possibile alla guida  
**Side Laser:** indicatore laser a linea sulla parte superiore della ruota per il posizionamento esatto dei pesi a molletta  
**Sonar EMS:** per misurare l'eccentricità (1<sup>a</sup> armonica e picco-picco) durante il normale ciclo, con indicazione immediata del matching possibile e HubMatch  
Fissaggio della ruota con **bloccaggio pneumatico** che garantisce una riduzione dei tempi di montaggio ed una maggiore precisione nel centraggio della ruota
- 3D Laser Scan:** système sans contact de mesure du déport et diamètre des roues, qui relève avec extraordinaire précision et vitesse les dimensions de tout profil. Le pointeur laser indique de forme univoque la position d'application de masses adhésives, assurant une précision maximale en phase de correction  
**Système sonar** pour la détection de la largeur de la jante  
**Déplacement automatique encore plus rapide et blocage de la roue** vers le point du positionnement des masses  
**OPB (One Plane Balancing):** si les conditions le permettent, OPB indique automatiquement le point exact à l'intérieur de la jante qui permet d'équilibrer la roue en minimisant à la fois le déséquilibre statique et le déséquilibre dynamique, en utilisant un unique contrepoids  
**AutoAdaptive Mode:** acquiert le poids et les dimensions de la roue et recalculé la valeur de tolérance de façon à annuler toute vibration perçue sur le volant, ce qui assure le meilleur confort de conduite possible  
**Side Laser:** faisceau laser sur la partie supérieure de la roue pour un positionnement exact des masses à agrafe  
**Sonar EMS** pour la mesure de l'excentricité (1<sup>ère</sup> harmonique et valeur crête à creux) pendant le cycle normal d'équilibrage, avec indication immédiate du possible matching et HubMatch  
Verrouillage de la roue par **bloccaggio pneumatico**, ce qui garantit une réduction des temps de montage et une haute précision du centrage de la roue
- 3D Laser Scan:** Touchless-System zur Messung von Radabstand und -durchmesser, das mit außerordentliche Präzision und Geschwindigkeit die Abmessungen eines jeden Profils erfasst. Der Laserpointer zeigt die richtige Position für das Aufbringen von Klebegewichten an und gewährleistet so maximale Präzision während der Korrektur  
**Sonarsystem** zur Erfassung der Felgenbreite  
**Noch schnellere automatische Radpositionierung und Radblokkieren** in dem Korrekturpunkt  
**OPB (One Plane Balancing):** liegen die Bedingungen vor, zeigt OPB automatisch den exakten Punkt an der Felgeninnenseite an, an dem das Rad ausgewuchtet kann und dabei sowohl die statische als auch die dynamische Unwucht mit einem einzigen Wuchtgewicht minimiert werden können  
**AutoAdaptive Mode:** die Software erfasst Radgewicht und -abmessungen und berechnet erneut einen Toleranzwert, mit dem jede am Lenkrad wahrgenommene Vibration ausgeschaltet und somit der bestmögliche Fahrkomfort garantiert werden können  
**Side Laser:** Laser-Pointer in Linie mit dem oberen Radbereich zur exakten Positionierung der Klammergewichte  
**EMS Sonar** zur Exzentrizitätsmessung (1. Harmonische und Spitze-Spitze-Wert) während des normalen Messlaufs, mit sofortiger Anzeige des möglichen matching und HubMatch  
**Pneumatische Radaufspannung**, die eine Verkürzung der Montagezeiten und eine hohe Genauigkeit bei der Radzentrierung garantiert
- 3D Laser Scan:** sistema touchless de medición de distancia y diámetro de la rueda que detecta con extraordinaria precisión y velocidad las dimensiones de cualquier perfil. El puntero láser indica la posición correcta para la aplicación de pesas adhesivas, asegurando la máxima precisión durante la fase de corrección  
**Sistema sonar** para detectar el ancho de la llanta  
**Posicionamiento automático aún más rápido y bloqueo de la rueda** en las posiciones de contrapeso  
**OPB (One Plane Balancing):** si se dieran las condiciones, OPB indica en automático el punto exacto en el interior de la llanta en el que se puede equilibrar la rueda; esto minimiza tanto el desequilibrio estático como el dinámico, utilizando un solo contrapeso  
**AutoAdaptive Mode:** adquiere peso y dimensiones de la rueda, y recalcula el valor de tolerancia para anular cualquier vibración percibida en el volante, asegurando el mayor confort posible en la conducción  
**Side Laser:** indicador láser de línea en la parte superior de la rueda para el posicionamiento exacto de los contrapesos de grapa  
**Sonar EMS** para la medición de la excentricidad (1<sup>a</sup> Armónica y Pico-Pico) durante el ciclo normal de equilibrado con indicación inmediata del posible matching and HubMatch  
Apriete de la rueda con **bloqueo neumático**, lo que garantiza tiempos de montaje reducidos y una mayor precisión al centrar la rueda

# STANDARD CONFIGURATION



## OPTIONAL ACCESSORIES

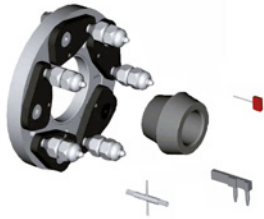

**UH20/2 Ø 40**  
Universal adapter 3-4-5-6 hole



**RL cup Ø 40**  
with rubber ring for alloy rims protection

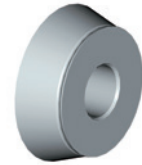

**J cone Ø 40**  
for cross-country and  
4WD wheels range Ø 101-119 mm



**WD spacer Ø 40**  
(Spacer for wide wheels) + DC spacer  
Ø 40 (to use together with WD)



**VL/2 cone Ø 40**  
Large cone for light truck 97-180 mm



**Special cone Ø 40** for central  
hole Ø 89/132 mm







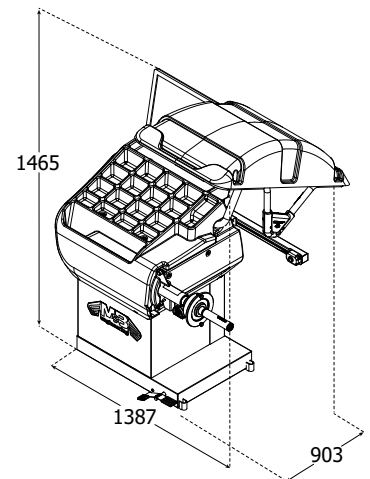
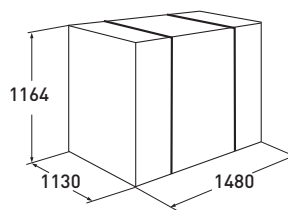



**EASY WEIGHT**  
Professional wheel lift  
capacity 80 kg

## OVERALL DIMENSIONS



## TECHNICAL DATA

								
170 kg	10" ÷ 30" 265 ÷ 765 mm	1.5" ÷ 20" 40 ÷ 510 mm	20" 508 mm	40" 1120 mm	< 75 kg	230V/1/50-60 Hz 115V/1/60 Hz	100 rpm	0,65



**M&B ENGINEERING SRL**  
Via Nobel, 21 - 42124 Reggio Emilia (RE)  
info@mb-re.it - www.mbenengineering.info